

IEA Combustion Agreement Fuel Spray Work 2008

Effect of Injector Geometry on the Development of Non-evaporating Diesel Spray



**Choongsik Bae
April 12, 2008
KAIST Engine Laboratory**



Objective

Two spring injector with VE pump

Solenoid injector with common-rail system

Piezo injector

Conclusions

Characterization of Diesel Spray

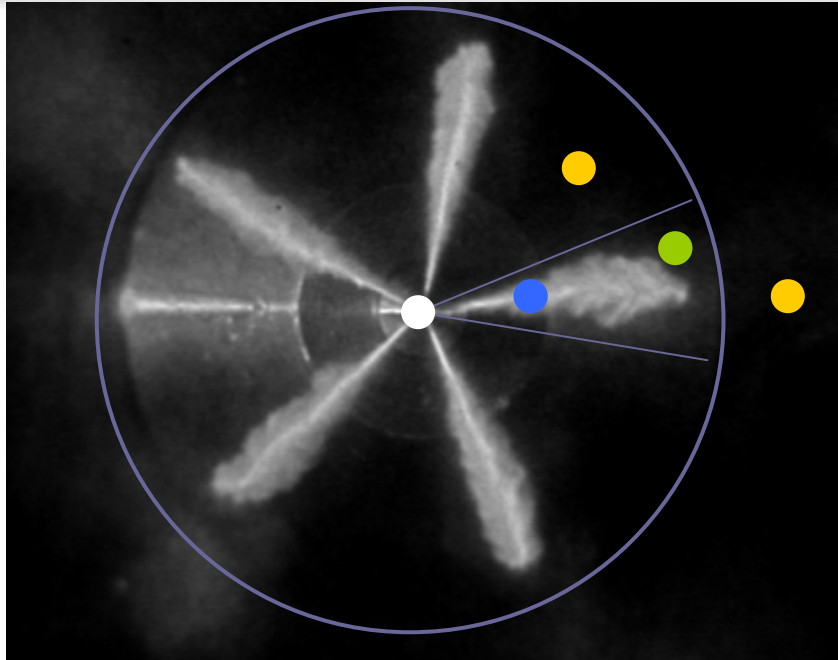

- To characterize real FIE under typical engine operating conditions



- To suggest useful guide lines to engine developers (somewhat qualitative and specific)

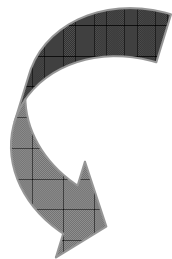

- **FIE simulation**
- **Liquid break-up models**
- **Visualization**
- **LDV, PDA, Microscopic imaging**

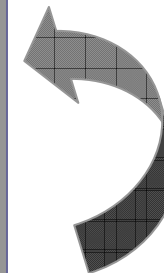

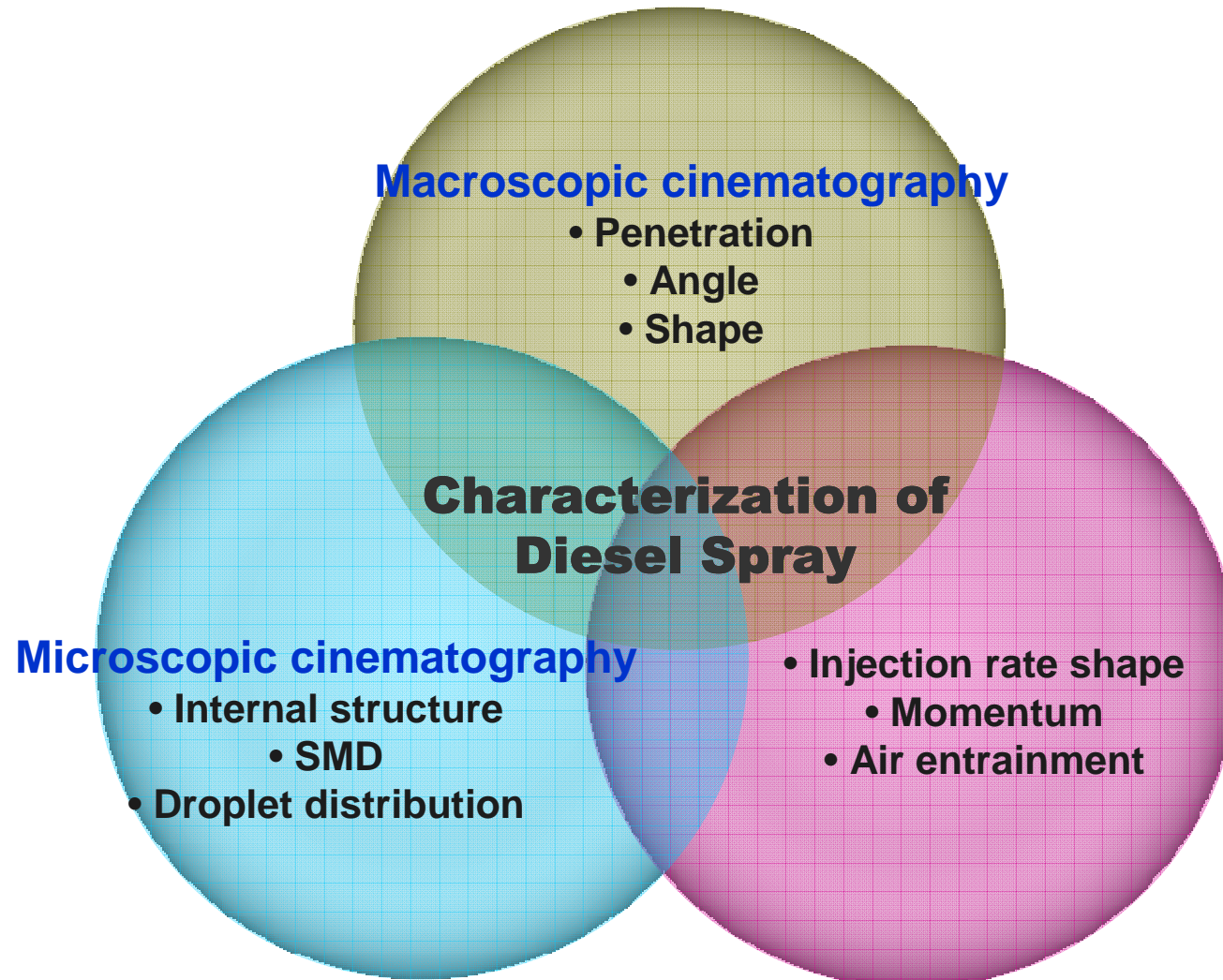

Injectors – two spring vs. solenoid

- a Injector closed (at-rest status),
- b Injector opened (injection).
- 1 Fuel return,
- 2 Electrical connection,
- 3 Triggering element (solenoid valve),
- 4 Fuel inlet (high pressure) from the rail,
- 5 Valve ball,
- 6 Bleed orifice,
- 7 Feed orifice,
- 8 Valve control chamber,
- 9 Valve control plunger,
- 10 Feed passage to the nozzle,
- 11 Nozzle needle.

Two-spring nozzle holder for direct-injection (DI) engines

- 1 Nozzle-holder body, 2 Shim,
- 3 Spring 1, 4 Pressure pin,
- 5 Guide element, 6 Spring 2,
- 7 Pressure pin, 8 Spring seat,
- 9 Shim,
- 10 Intermediate element,
- 11 Stop sleeve,
- 12 Nozzle needle,
- 13 Nozzle-retaining nut,
- 14 Nozzle body,
- h_1 Initial stroke,
- h_2 Main stroke.

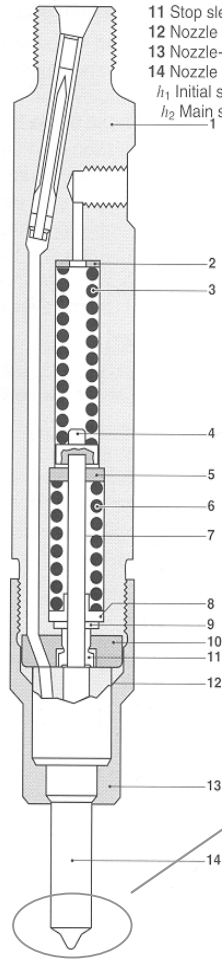

Two spring injector (BOSCH VE pump)

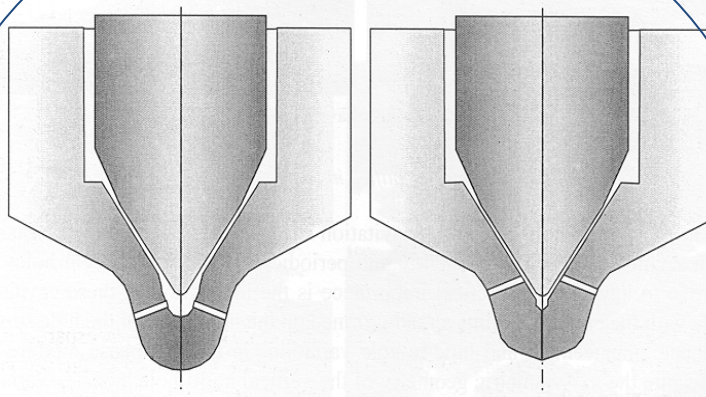

Sac Nozzle

VCO Nozzle

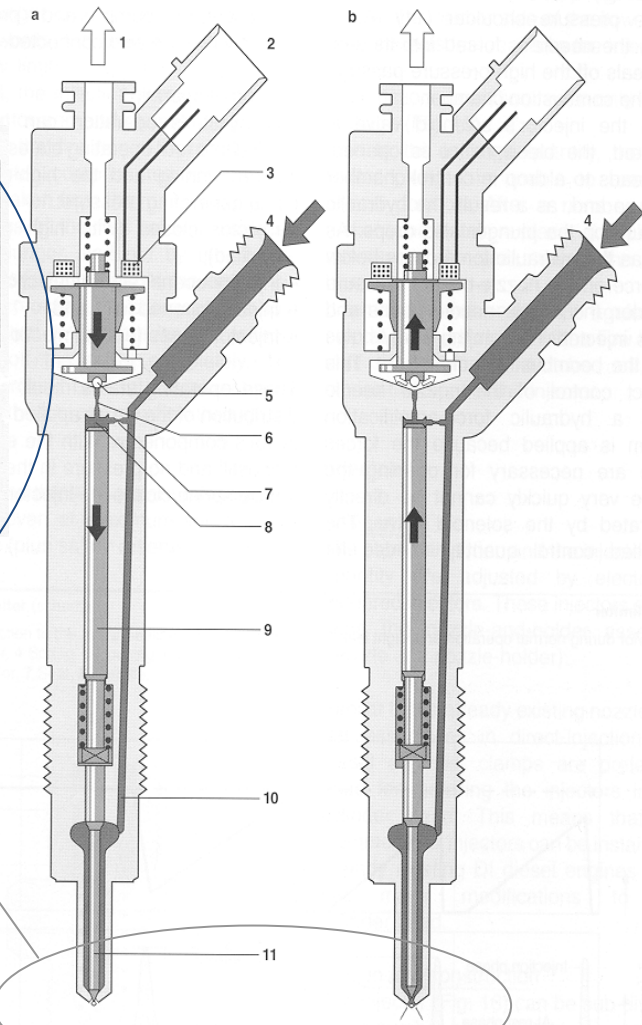

Common-rail system injector

VCO NOZZLE IN TWO SPRING INJECTOR WITH VE PUMP SYSTEM

VCO Nozzle: hole to hole variation

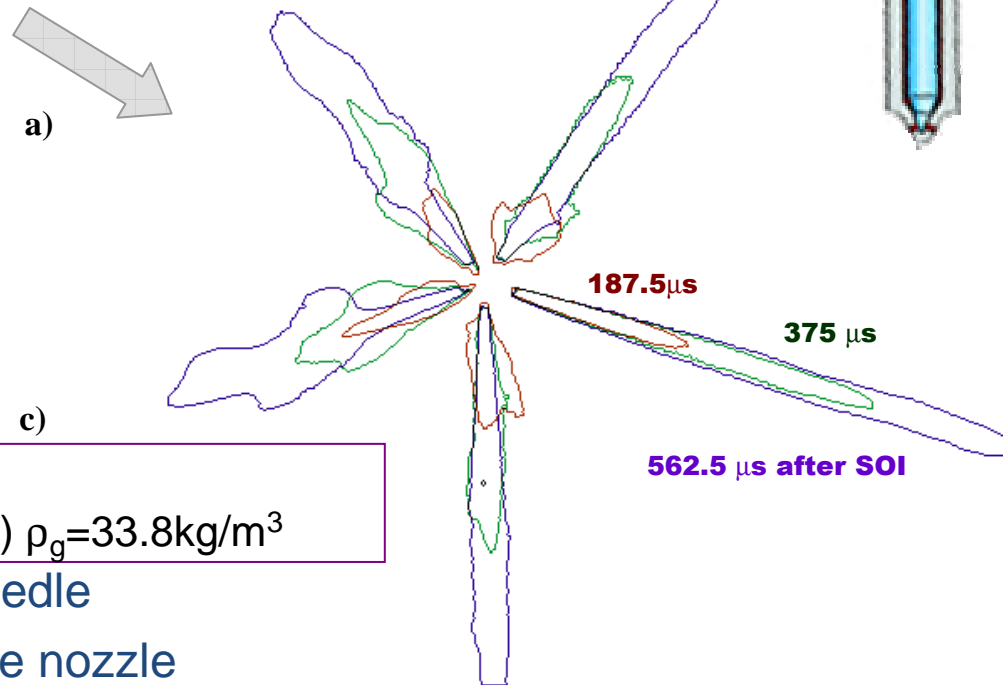
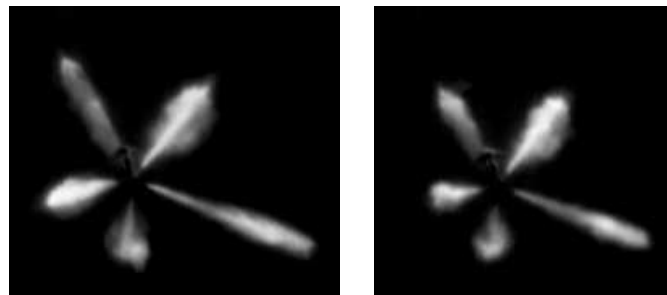
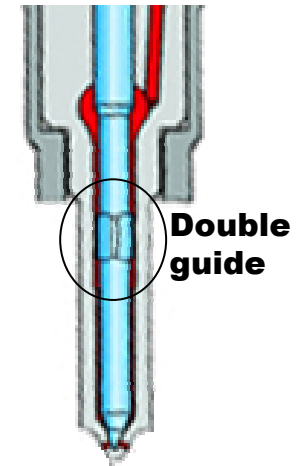
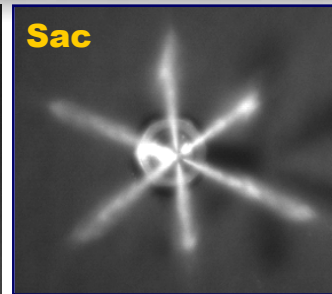
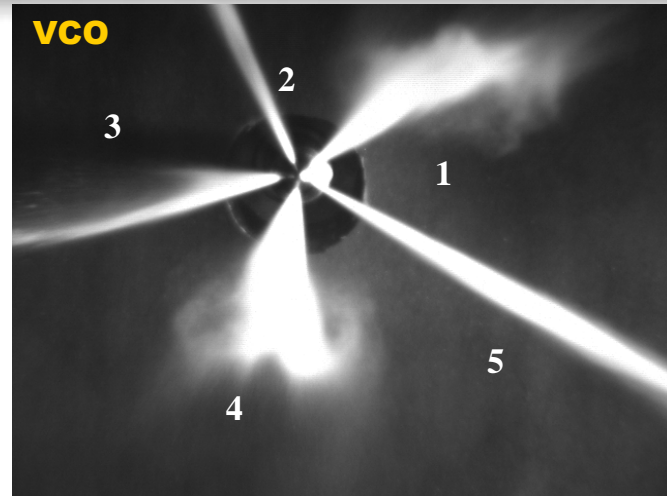

VCO nozzle, 0.1ms after SOI

a) $\rho_g=1.23\text{kg/m}^3$, b) $\rho_g=16.9\text{kg/m}^3$, c) $\rho_g=33.8\text{kg/m}^3$

- Eccentricity of single guided needle
- Uneven pressure field inside the nozzle
- Three distinct initial spray shapes

VCO Nozzle: Spray tip penetration

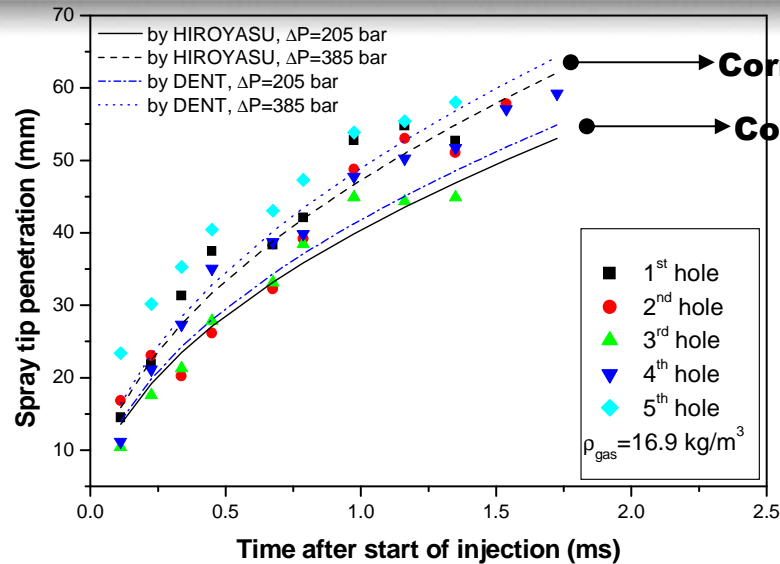

Corresponding to maximum injection pressure

Corresponding to opening pressure

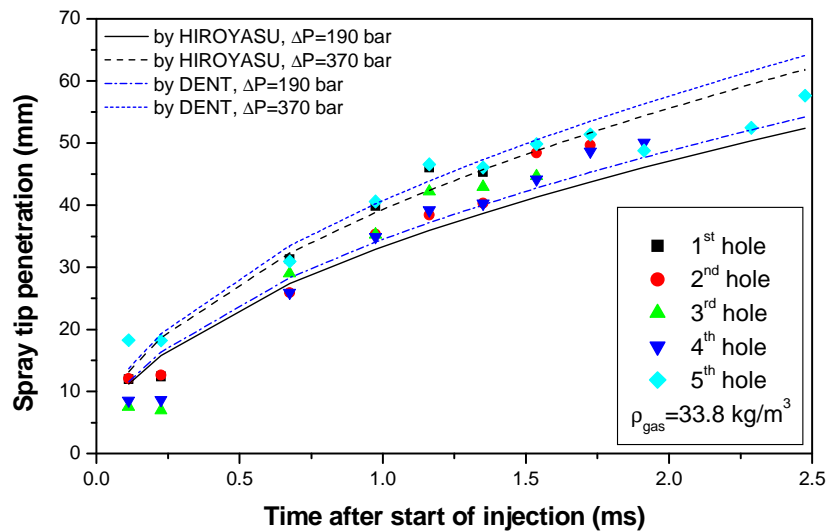

VCO nozzle, $m_{\text{inj}}=3.14\text{mg}$

By Hiroyasu et al. (1990)

$$S = 0.39 \left(\frac{2\Delta P}{\rho_1} \right)^{1/2} t \quad t < t_{\text{break}}$$

$$S = 2.95 \left(\frac{\Delta P}{\rho_g} \right)^{1/4} (D_o t)^{1/2} \quad t > t_{\text{break}}$$

$$\text{Where } t_{\text{break}} = \frac{28.65 \rho_1 D_o}{(\rho_g \Delta P)^{1/2}}$$

By Dent (1971)

$$S = 3.07 \left(\frac{\Delta P}{\rho_g} \right)^{1/4} (D_o t)^{1/2} \left(\frac{294}{T_g} \right)^{1/4}$$

SAC Nozzle: Injection Fluctuation

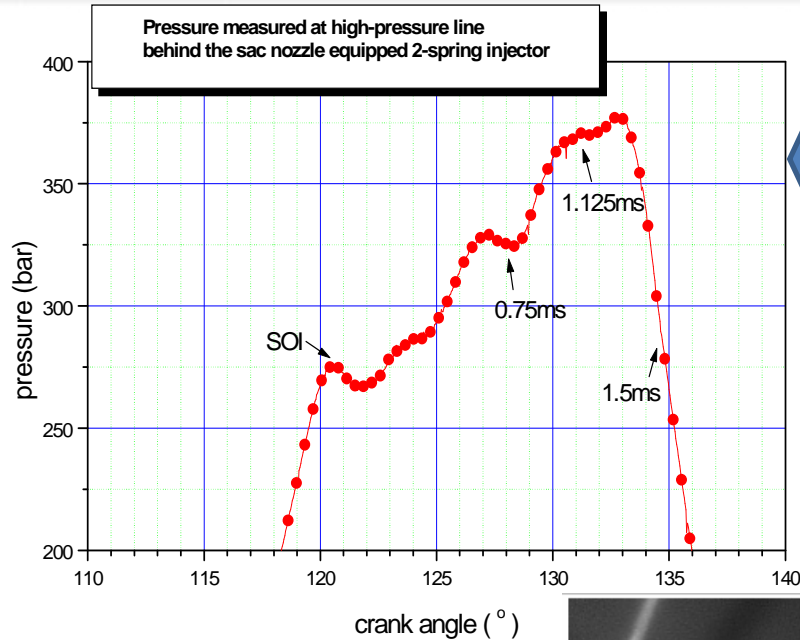

Pressure measured at high pressure line between Bosch VE pump and 2-spring injector with mini-sac nozzle [1600 eng. rpm, $m_{inj}=55.3\text{mg}$]

Spray shapes in accordance with pressure fluctuation

(spray from sac nozzle of 2-spring injector which is connected to BOSCH VE pump)

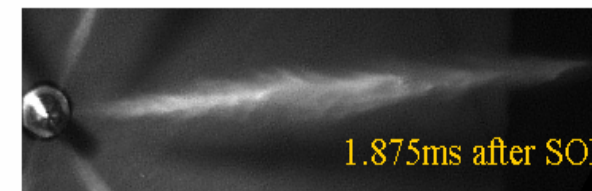
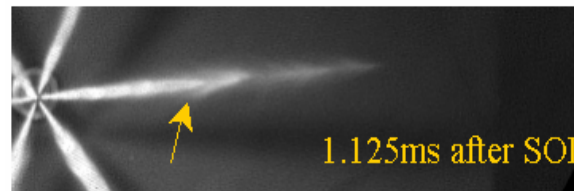
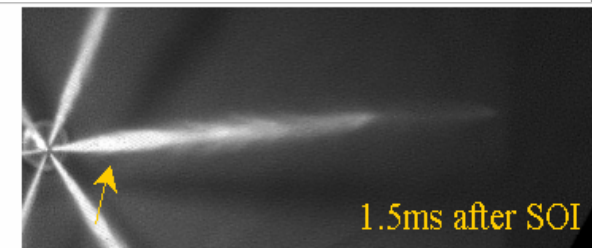
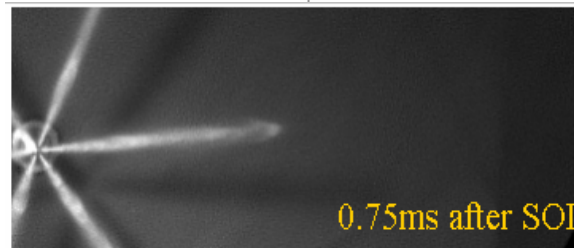

Spray from a VCO nozzle at hole 5

-Two spring injector

- Spray pattern is similar to that of multi-hole sac nozzle
- Spray pattern and angle didn't change during injection period

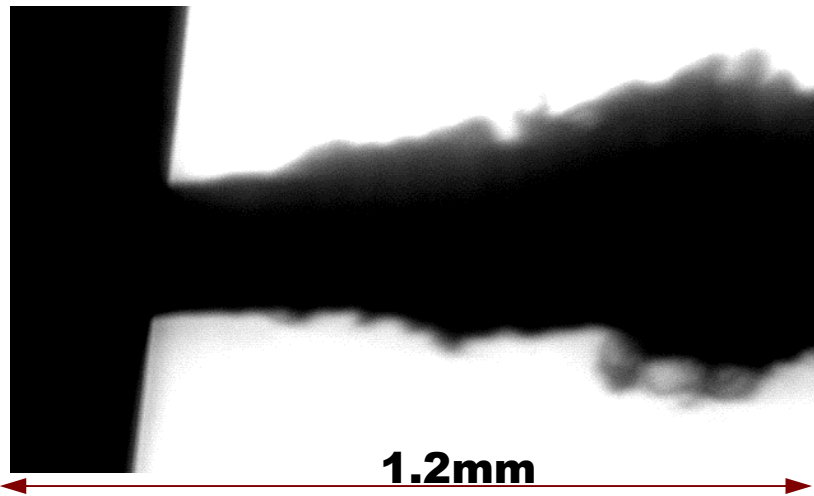

1600 engine rpm

0.2ms after SOI,

$\rho_{\text{gas}}=1.23\text{kg/m}^3$, $m_{\text{inj}}=29.4\text{mg}$

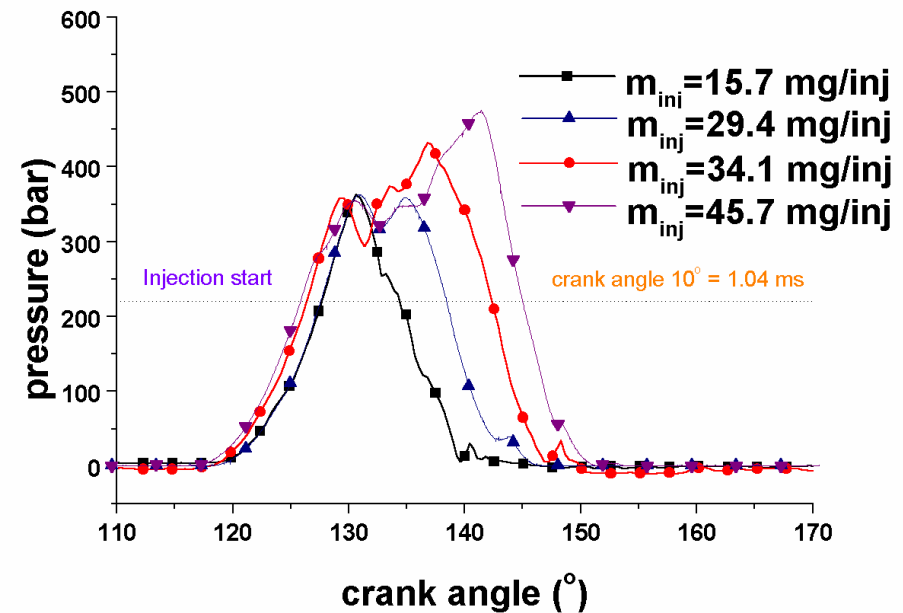

Spray from a VCO nozzle at hole 4

-Two spring injector

- Hollow cone type spray
- About 0.7ms later sac type spray appears as hole-to-hole variation disappears
- At the end of injection ligaments are trickled down large drops (scores of μm)

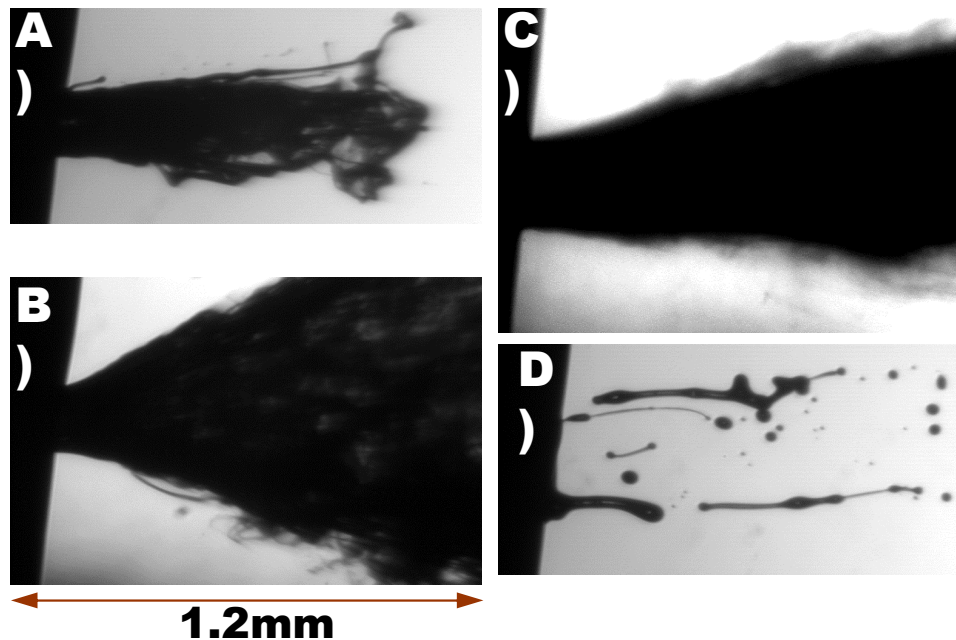

1600 engine rpm $m_{inj}=29.4\text{mg}$
a) start of injection
b) 0.2ms later
c) 0.7ms later
d) end of injection

COMMON-RAIL INJECTION SYSTEM

Spray Pattern of Solenoid Injector in a CR system

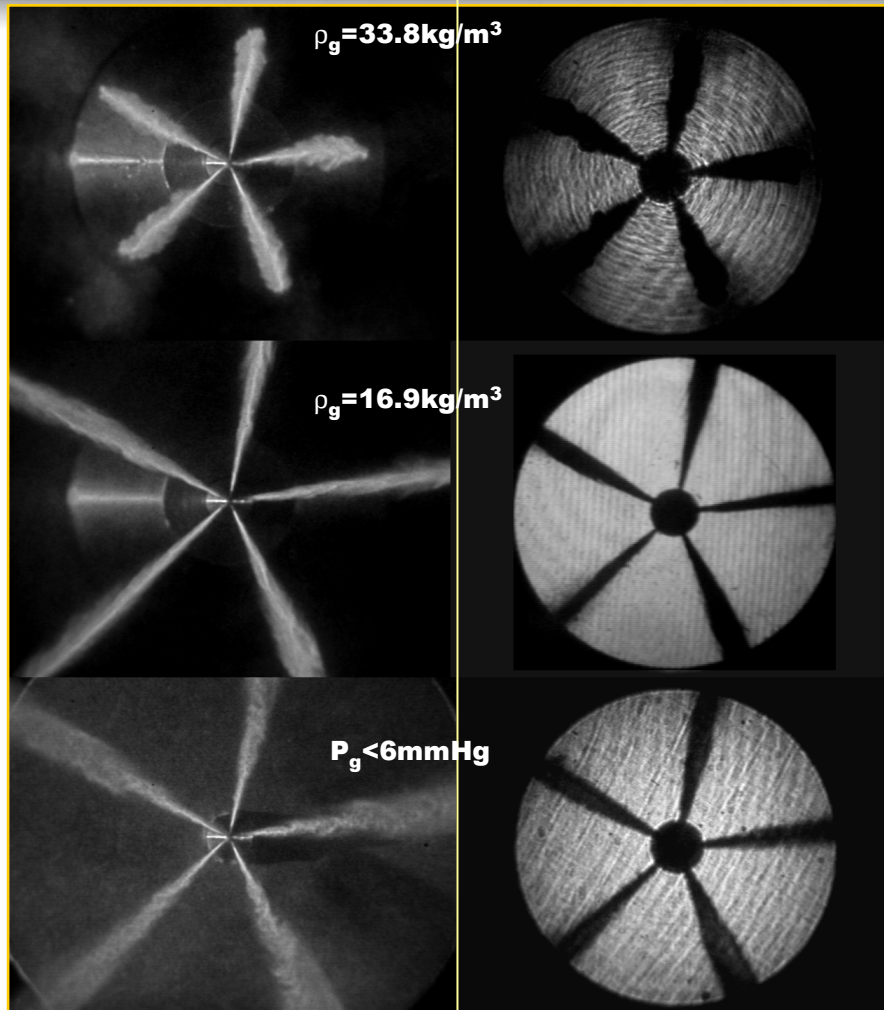

Mie scattering, VCO

Shadowgraph, VCO

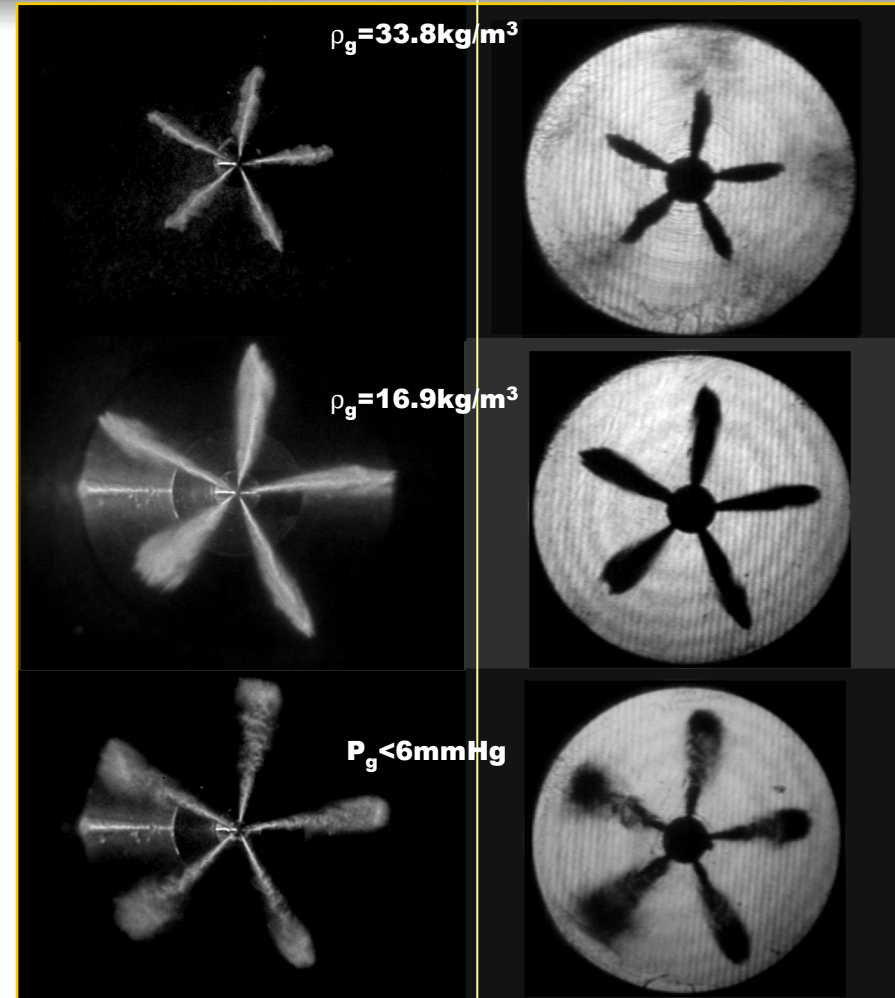

Mie scattering, SAC

Shadowgraph, SAC

$P_{\text{rail}} = 1120 \text{ bar}$, 0.25ms after SOI

$P_{\text{rail}} = 1120 \text{ bar}$, 0.16ms after SOI

Effect of Injector Geometry on the Development of Non-evaporating Diesel Spray

VCO vs. SAC nozzle

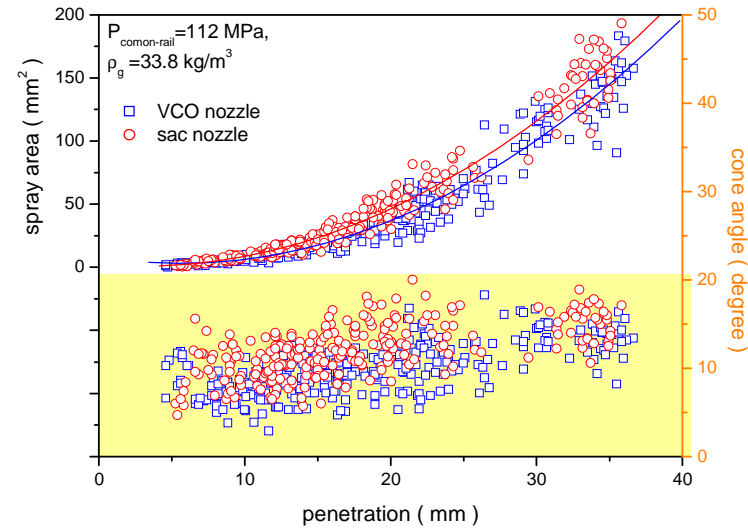
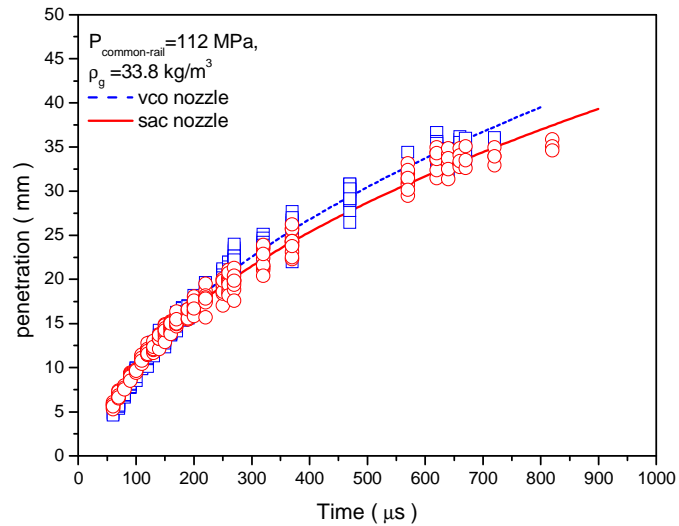
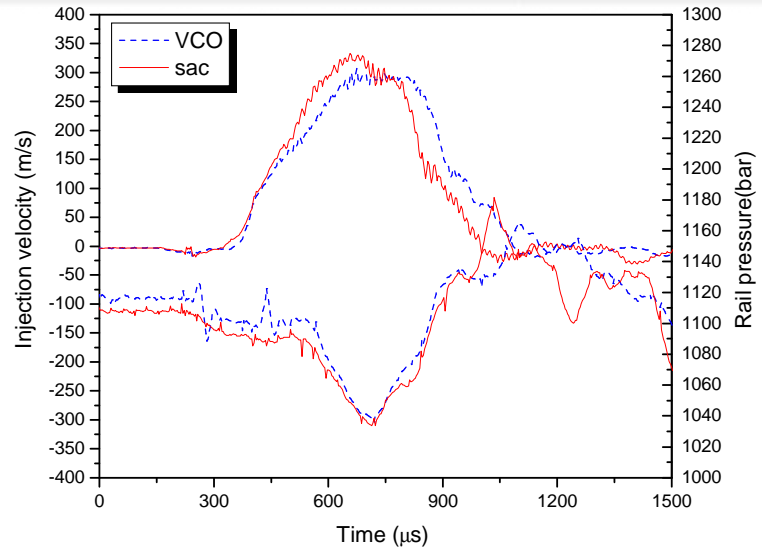
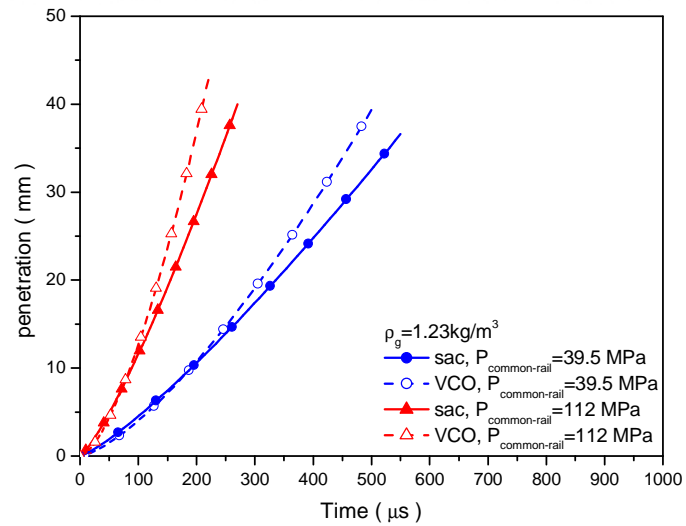

VCO Nozzle: Spray Angle vs. CR Pressure

- Spray angle increase according to rail pressure
- Spray angle variation increase according to rail pressure
- Air entrainment increases spray volume

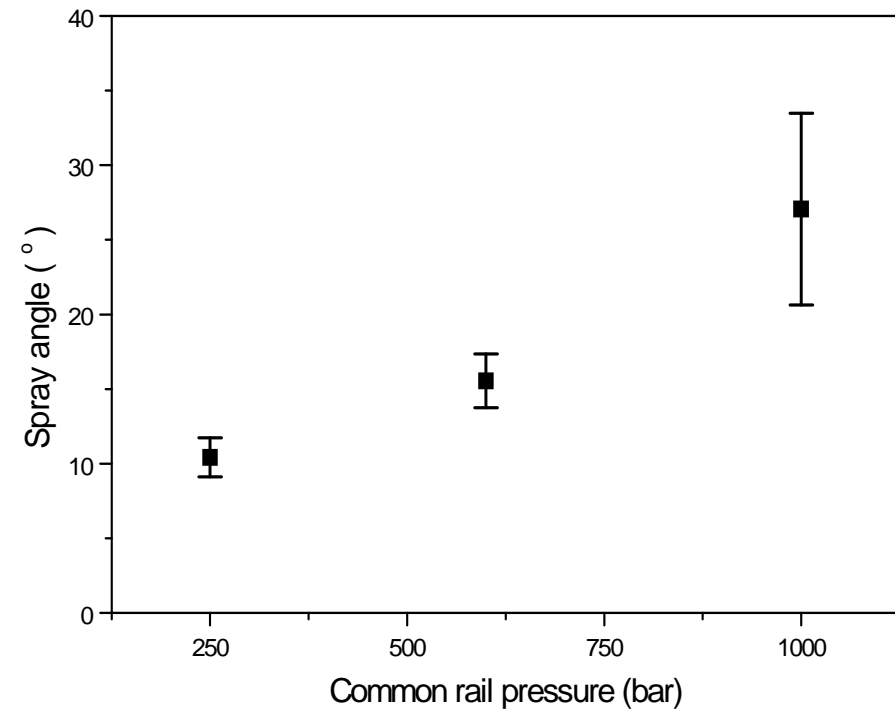
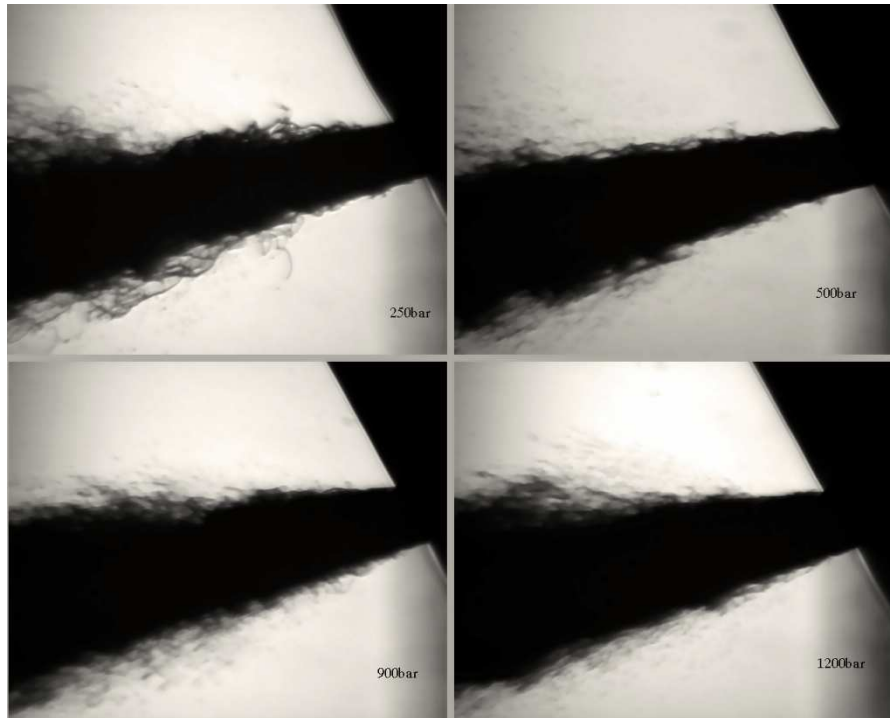

Initial Spray Development from a VCO Nozzle

Liquid membrane deformation, Non-symmetric wave, Ligaments forming, Atomization regime

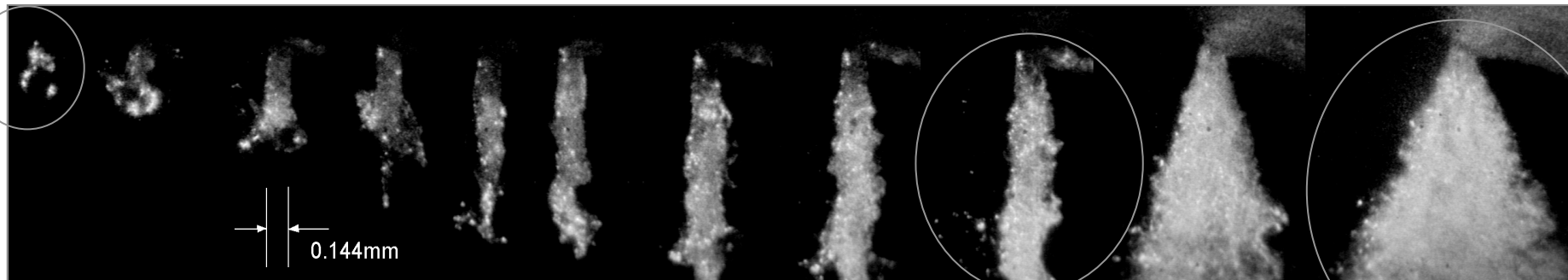

Injection pressure=250bar, $\rho_{\text{gas}}=1.23\text{kg/m}^3$ (from left : 3, 5, 10, 15, 20, 25, 30, 40, 50, 100, 150 μs after SOI)

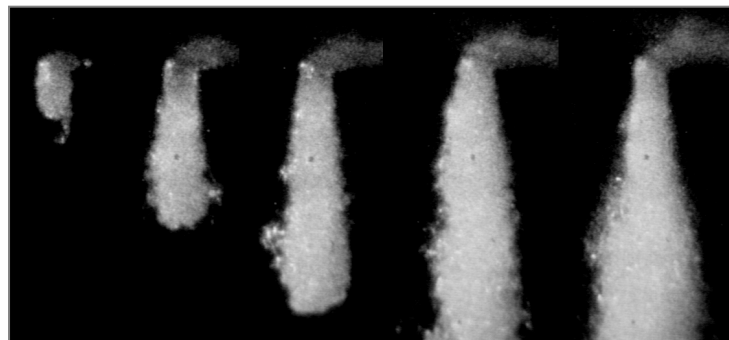

Injection pressure=1200bar, $\rho_{\text{gas}}=1.23\text{kg/m}^3$
(from left : 4, 6, 14, 19, 24 μs after start of injection)

At high injection pressure

- No distinct transition to atomization regime is observed
- Scattered light intensity distribution from spray cross section is uniform

Microscopic Spray Cinematography from a VCO Nozzle

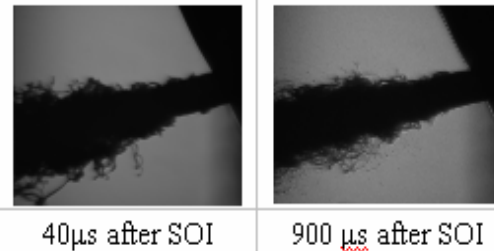
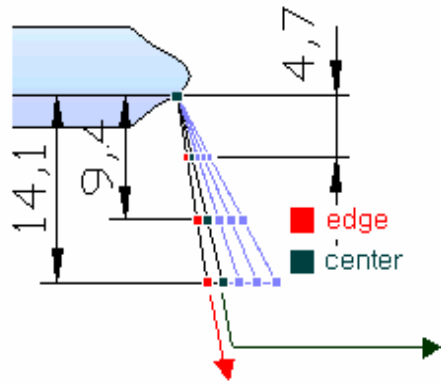

0mm

40 μ s after SOI

900 μ s after SOI

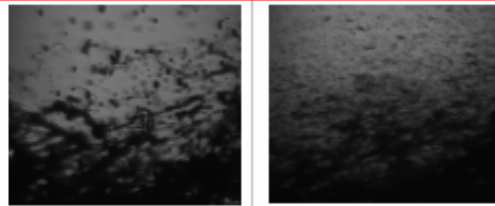

140 μ s

1190 μ s

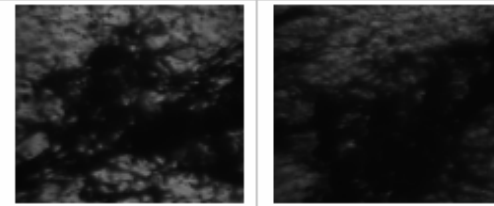

140 μ s

1190 μ s

4.7mm

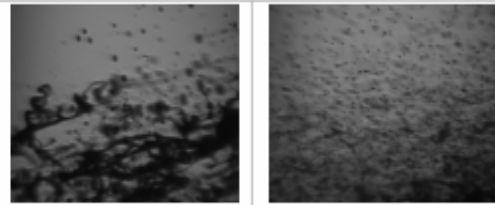

190 μ s

1540 μ s

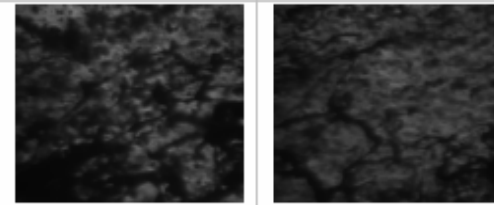

190 μ s

1540 μ s

9.4mm

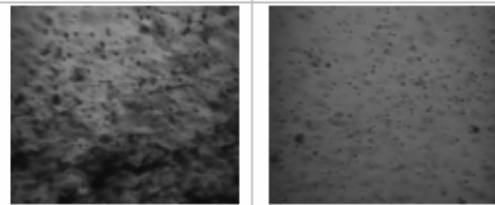

260 μ s

1760 μ s

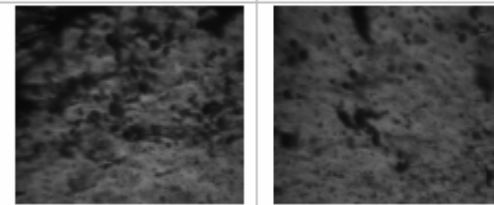

260 μ s

1760 μ s

14.1mm

Spray edge (80° line of Fig. 2-10)

Spray center (75° line of Fig. 2-10)

Atomization Characteristics of VCO Nozzle

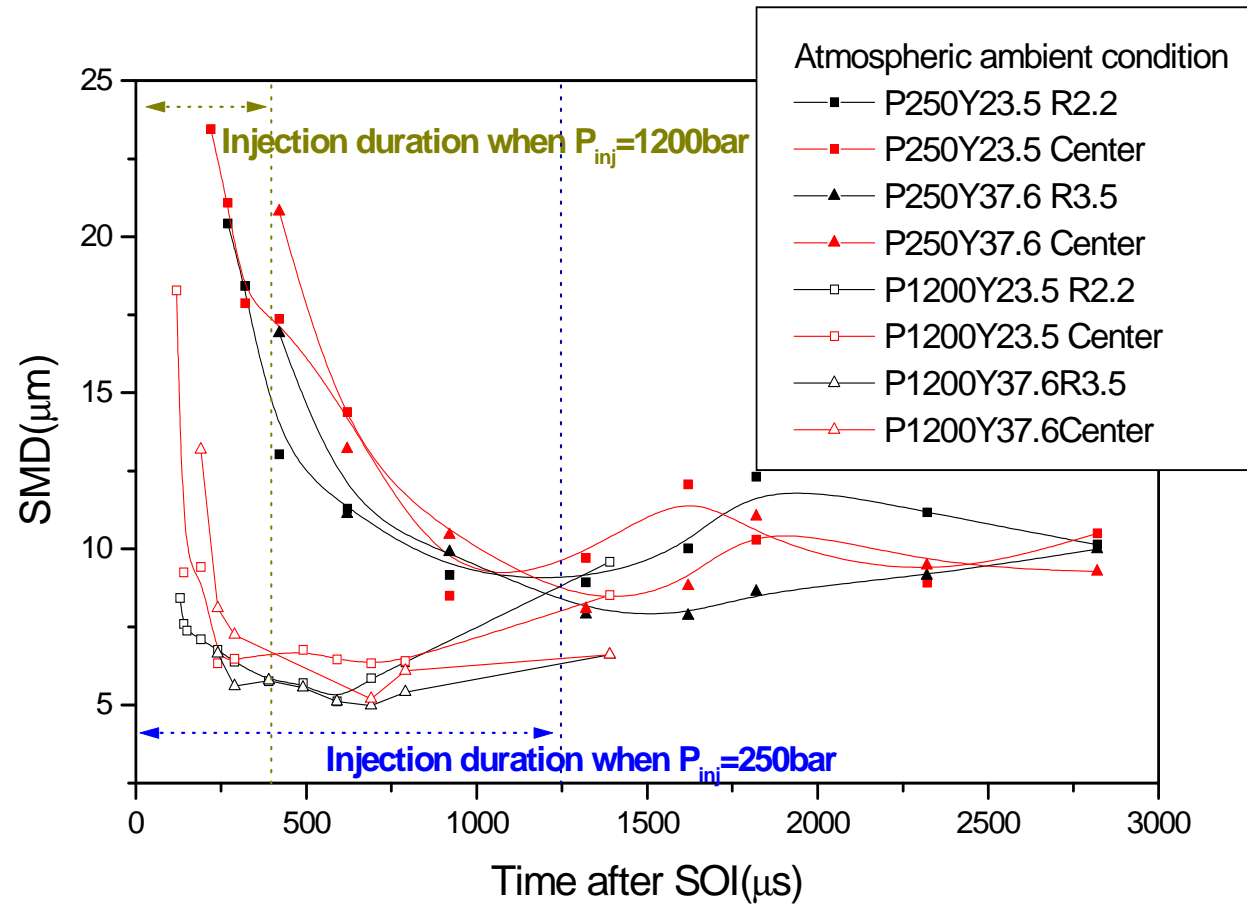

A model for development of transient diesel spray

Air entrainment increase spray volume, augmented by radial velocity component of turbulence

Volume flow rate of ambient air

Bubbles collapse inside liquid column leaving void parts

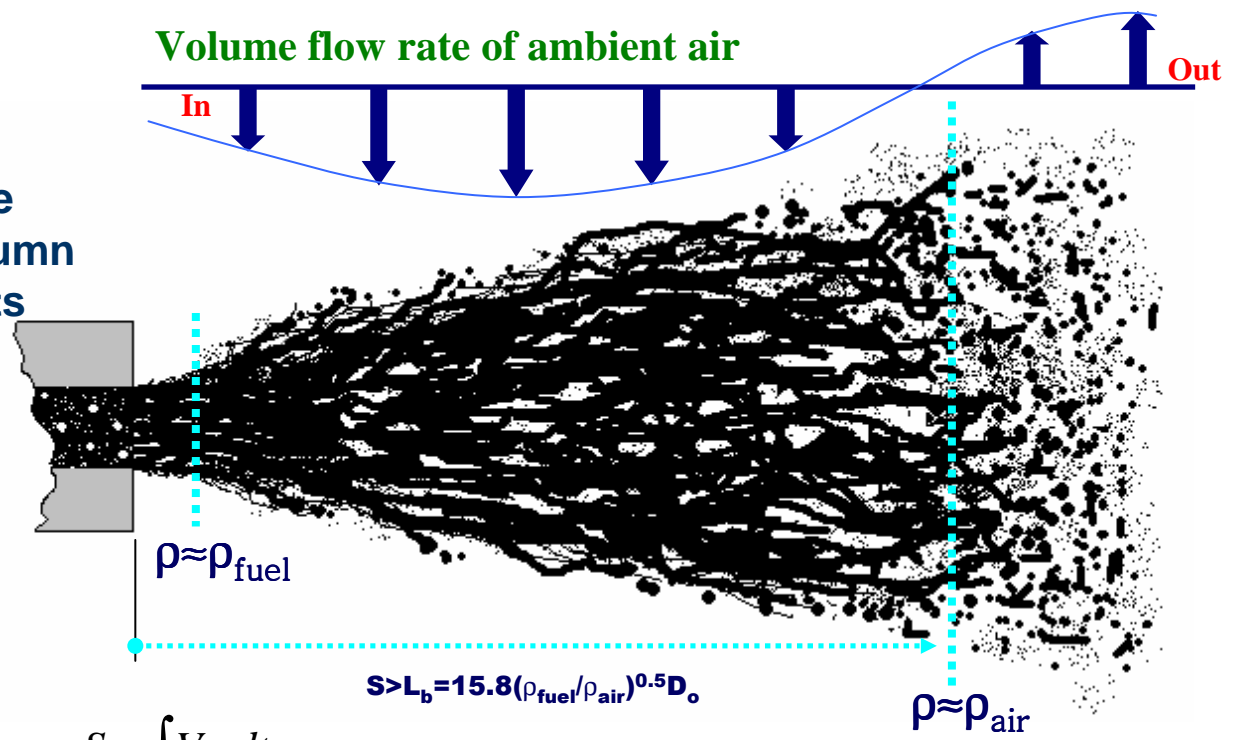

$t \rightarrow 0$

$$S = \int V_{inj} dt$$

$$t \gg \left(\frac{\rho_{fuel}}{\rho_{air}} \right)^{0.5} \frac{D_o}{V_{inj}}$$

$$S = const. \left(\frac{momentum}{\rho_{spray}} \right)^{0.25} t^{0.5}$$

Most droplets are formed at the end of ligaments

Fuel injection system	Injector	Nozzle type	Ambient gas density
Common-rail	Solenoid type, Double-guided	VCO, 6hole x 148°	1.23kg/m ³
			16.9kg/m ³
			33.8kg/m ³

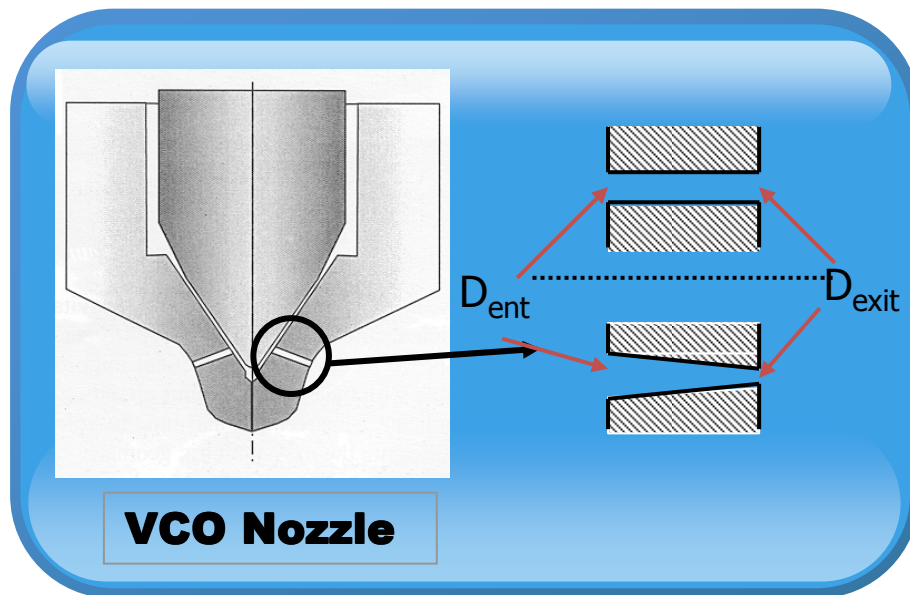

▪ Nozzle Geometry

K factor	D_{ent} (mm)	D_{exit} (mm)
0	0.132	0.132
1.5	0.144	0.129
2	0.146	0.126

K factor: Injection rate and Spray tip penetration

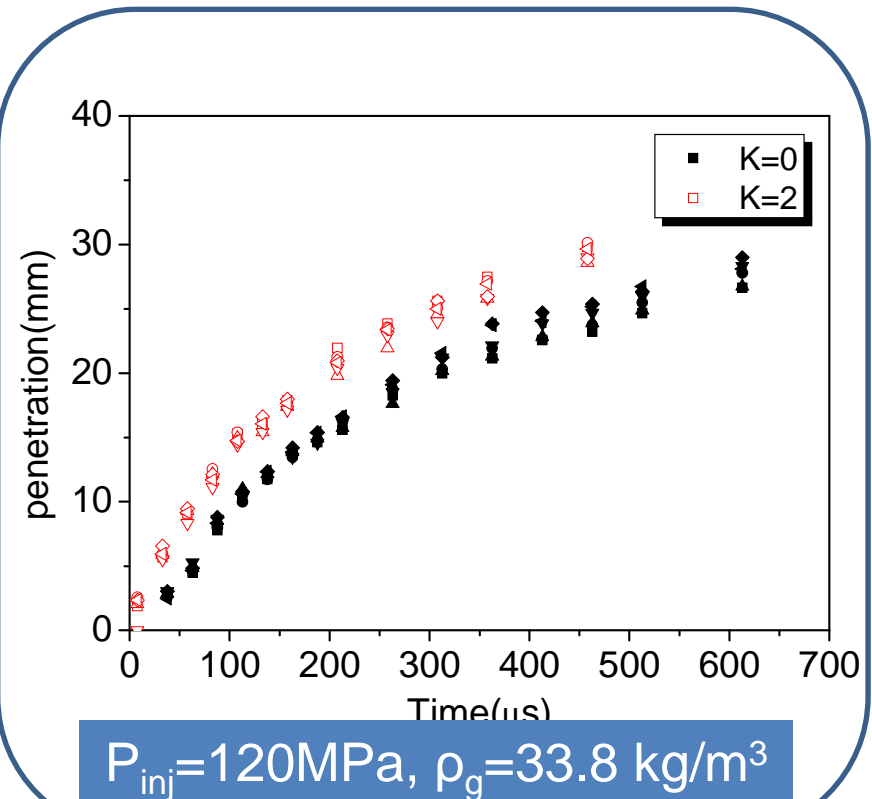
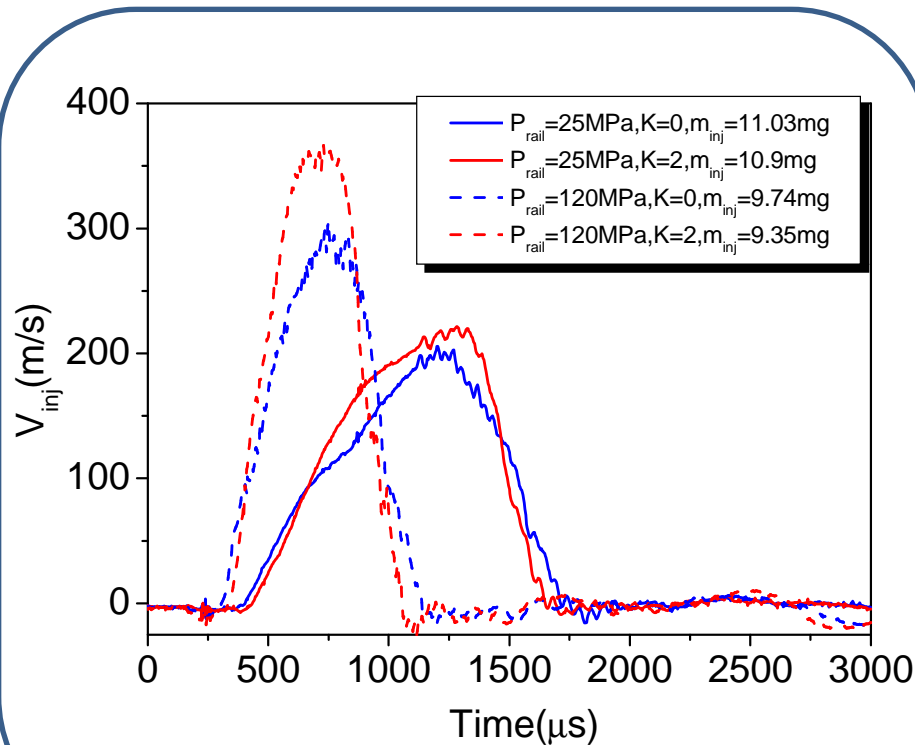

- As increased K factor, injection velocity is increased rapidly and peak velocity is higher.
- Also spray tip penetration of K factor, 2 nozzle is higher than that of K factor, 0 nozzle.

K factor: Spray angle and Entrainment coefficient

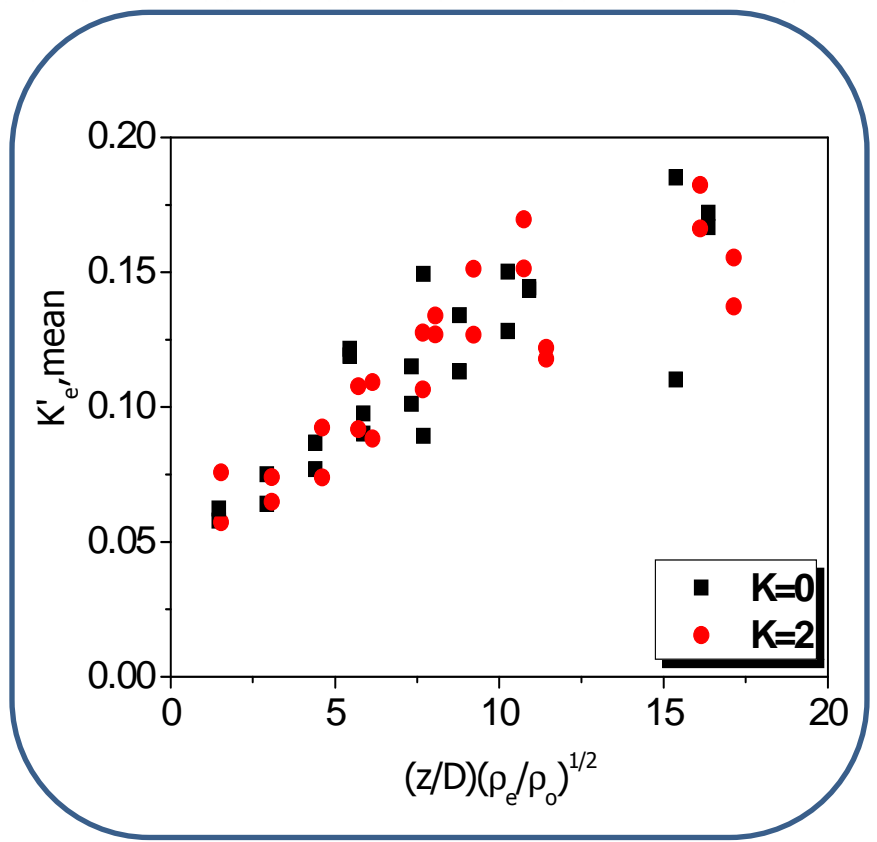
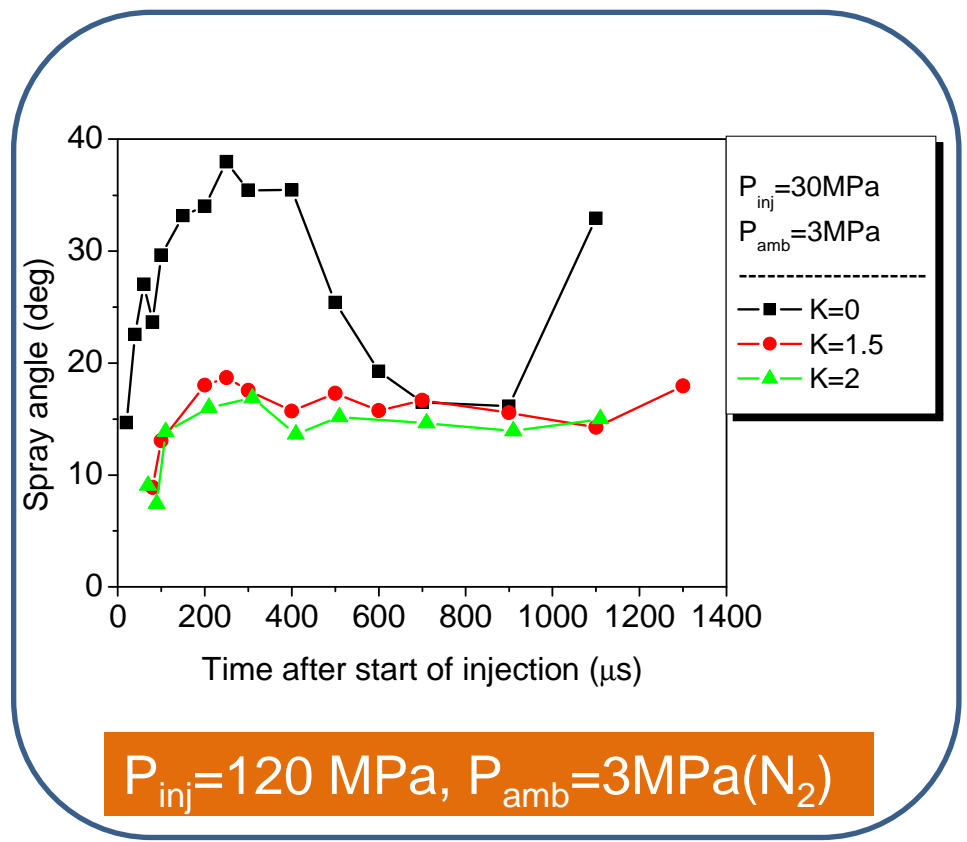

- As increased K factor, spray angle is decreased.
- Air entrainment quantity is same.

K factor: Droplet size

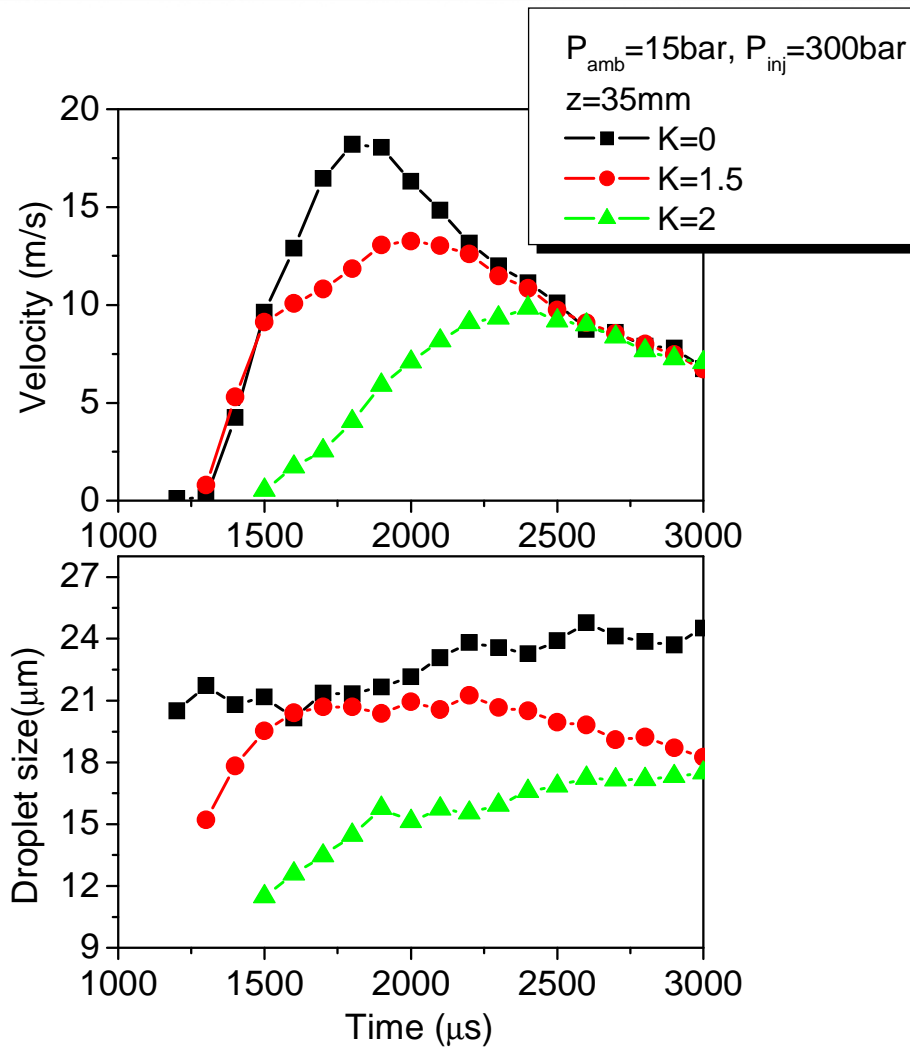

Ambient pressure: 1.5 MPa
 Injection pressure: 120 MPa
 Injection volume: 11.5 mm³
 Axial Position: 35mm

Increase the K factor
(tapered)



Faster injection
velocity at a nearby
nozzle

- Decrease in droplet mean velocity
- Decrease in droplet mean diameter

K factor: SMD

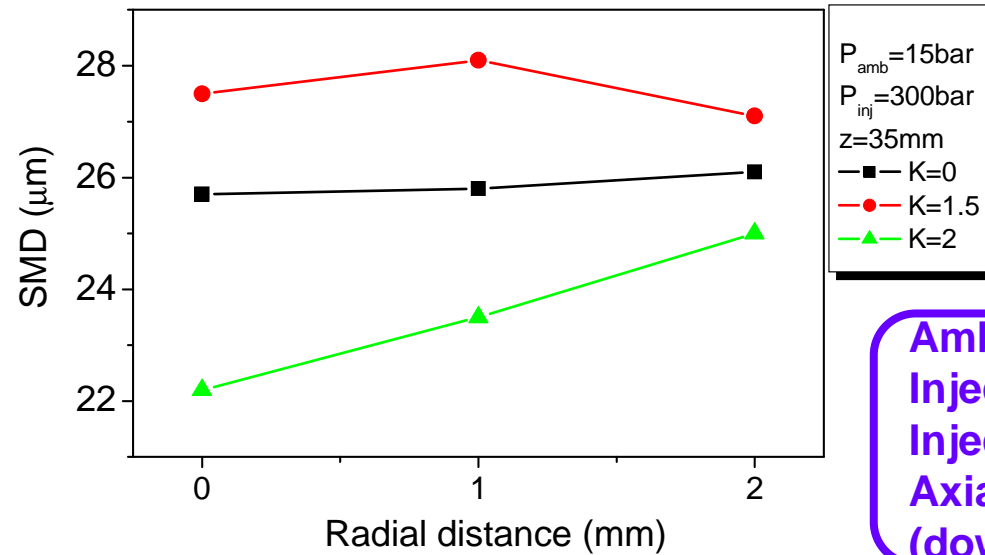

Ambient pressure: 1.5 MPa
 Injection pressure: 30 MPa
 Injection volume: 11.5 mm³
 Axial Position: 35mm
 (downstream)

- As the k factor increases, the SMD decreases due to the small droplet size

Piezo electric actuated injector

Piezo vs. Solenoid injector

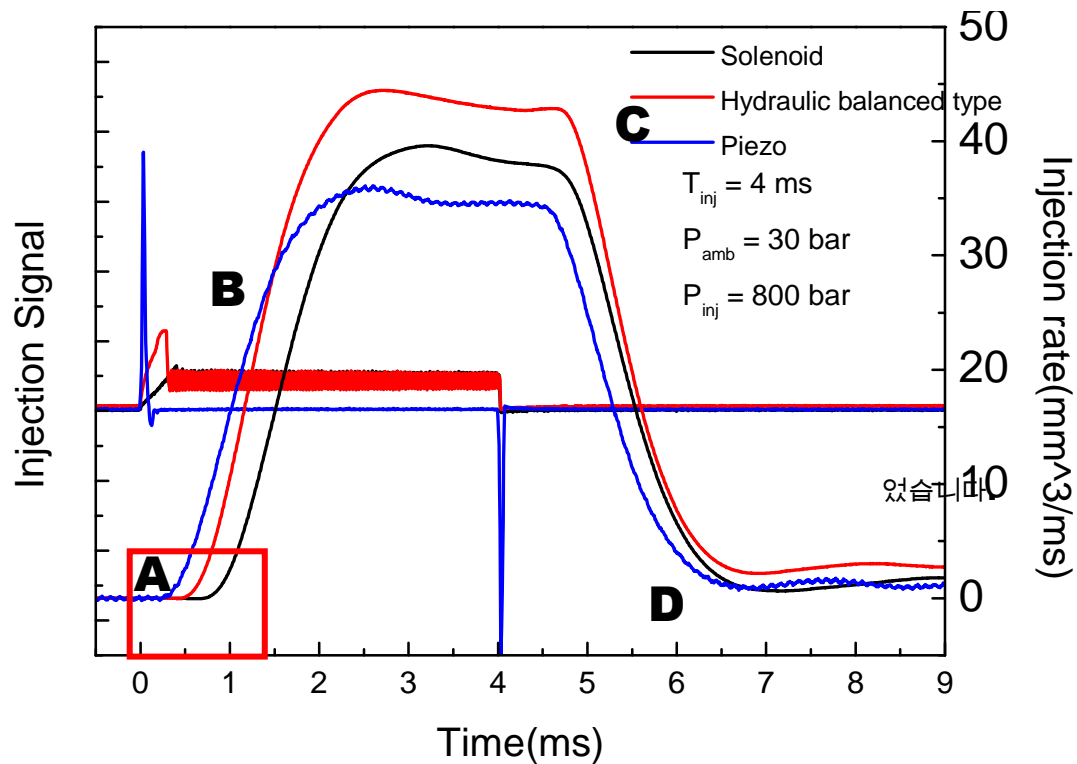

Type	# of Hole	Inj. Angle(°)	HFR (cc/30s)
Solenoid	7	150	400
Hydraulic Balanced Type	8	155	500
Piezo	6	153	360

- A → Section of response to injection signal
- B → Section of initial rising rate
- C → Section of response to needle closing signal
- D → Section of falling rate

Response of injection opening

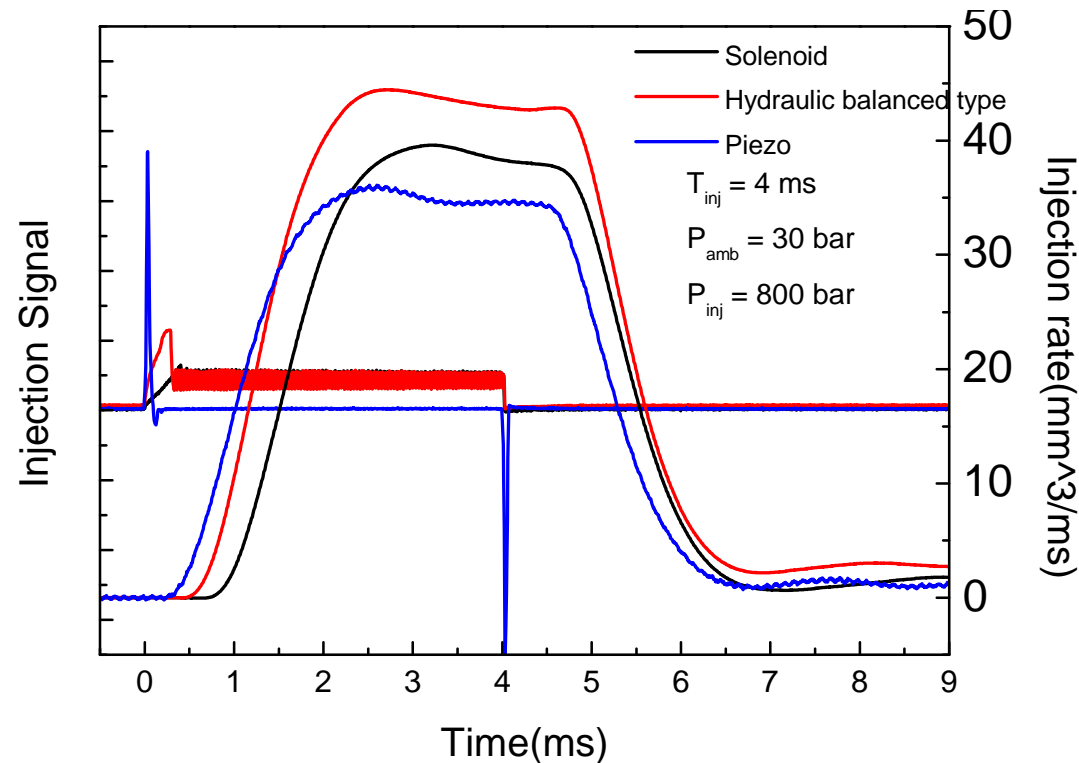

- Initial response time : Piezo > Hydraulic balance type > Solenoid

Conclusions

- VCO nozzle with single-guided needle has a hole to hole variation in initial spray shapes.
- Spray shapes in accordance with pressure fluctuation is varied in VE pump system.
- At low needle lift condition of two spring injector, spray pattern and angle didn't change during injection period.
- In common-rail system, spray angle and variation increased according to rail pressure.
- At high injection pressure, distinct transition to atomization regime is not observed.
- As increased K factor, initial injection velocity is increased and spray tip penetration is farther and spray angle is smaller.
- The onset of injection of from piezo injector is faster than that of solenoid injector.